

OFFICIAL CUT SHEET

1 PIECE OVERSIZED PRACTICE MOUND

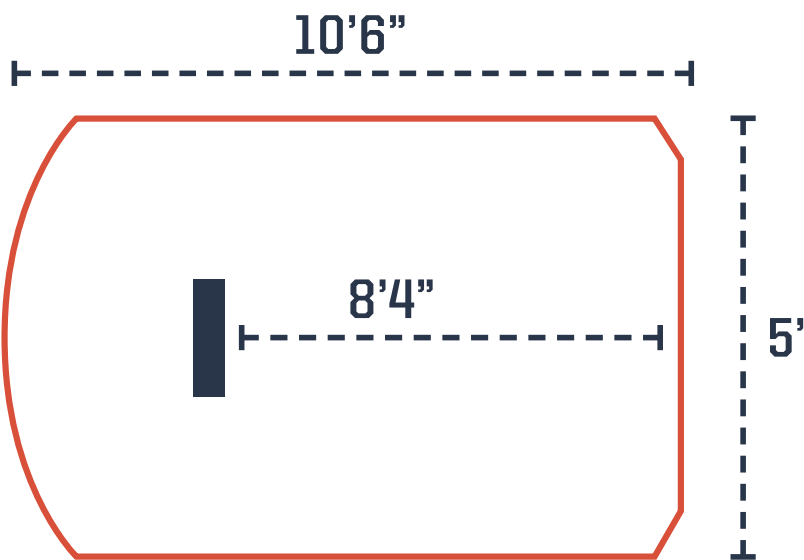

800.315.8115
INFO@PORTOLITE.COM

ITEM 1175COLOR1PC

CATEGORY Game Mounds



HIGH DENSITY
FOAM CORE



INCAPSULATED IN
SUPER LIGHT
WEIGHT FIBERGLASS



COATED POLYUREA

Product Features

Extra large for the tallest pitchers, longest strides and extra "noisy" wind ups. Larger back area to practice pick off moves.

- Removable Pitch Pad
- Removable Rubber

Product Specifications

Dimensions	10"H x 10'6"L x 5'W
Weight	160 lbs.
SpikeTek	Spikes prevents movement
Turf	Clay, Green, Tan, Red, Brown

